

4 - PULSING MODE / RETENTIVE MODE

The sensor can also be used as a switch to activate loads, as lamps or small products that do not exceed the current of 1.5A and 60W, for this it is necessary to change the operation mode of the pulsating sensor for retention. To make this change sufficient you just need to take out the jumper contacts ("P/R") as to show the icon 6. (JUMPER "P / R" CLOSED) = PULSING MODE;
(JUMPER "P / R" OPEN) = RETENTIVE MODE;

5 - DISTANCE ADJUSTMENT FOR EXTERNAL ENVIRONNEMENTS

If the sensor is installed in an external environment with high clarity, it is necessary to change the functioning of the sensor, to 25cm as this the sensor will function better even with the interference of clarity.

To do this, simply remove the jumper from the contacts ("+/-") as shown by the icon 5, which the sensor will already start detecting with more distance.

G•ACCESS

6 - INSTALLATION

To attach the sensor to the wall, remove the screws from the top and bottom of the front cover, use screws with thread and nut to attach the box on the 4x2 mirror, and use the screws to attach the mirror to the wall

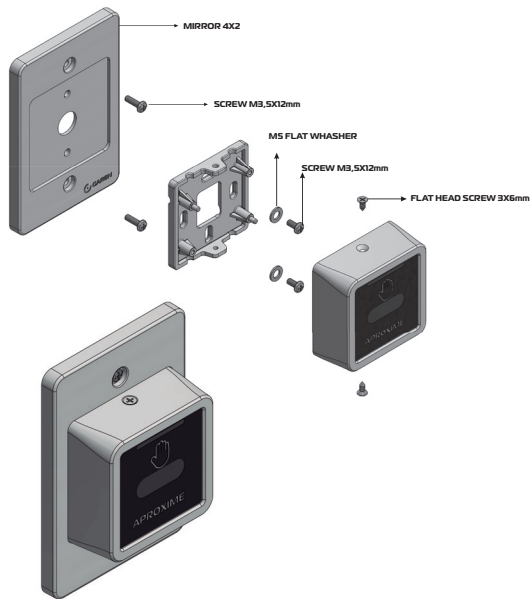

G•ACCESS

Manual

PROXIMITY BUTTON GA P01B

XXXXXX

G•ACCESS



GAREN
PROXIMITY BUTTON

CENTER BUTTON

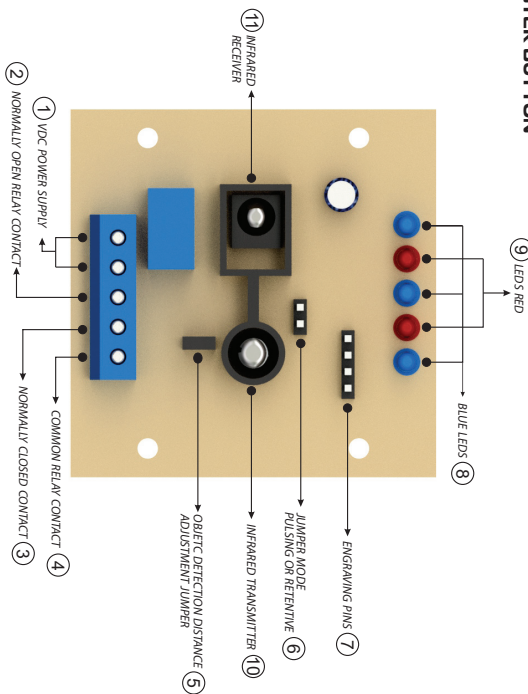

- 01-12VDC power supply;
- 02-Normally open relay contact;
- 03-Normally closed relay contact;
- 04-Common relay contact;
- 05-Object detection distance adjustment jumper;
- 06-Pulsing or retentive jumper;
- 07-Engraving pins;
- 08-Blue LEDES (Activated when it detects an object);
- 09-Red LEDES (Activated when looking for an object);
- 10-Infrared emitter;
- 11-Infrared receiver

1 - CHARACTERISTICS

Power 12VDC;
Detection at 15cm or 25cm;
Operation mode for indoor or outdoor environments;
Pulsing mode for commands to open doors or derivatives;
Retentive mode for load up to **60W**;
Standby consumption current (relay off) 25mA;
Consumption current in operation (relay on) 38mA;

2 - RELAY SPECIFICATION FOR ACTIVATING LOADS

Contact material: Silver alloy;
Maximum contact current: 1.5A;
Maximum load power: 60W.

3 - CONFIGURATION

When powering the sensor, it will already be operating in the standard factory mode (pulse mode and 15cm detection distance).

To send a pulse, just place your hand on the front of the sensor at a distance of 2 to 15 cm. When detecting the approach, the red LED will go out and the blue LED will light, signaling that the sensor has found some object.